



# HS17 D4H OROPS 2 LEG EARLY STYLE Installation Instructions

## Tools Needed

- Forklift or Overhead Hoist
- 1-1/2" Wrench (2)
- Rubber Mallet (1)

## Parts List

- SP0069 RH Fender Mount (1)



- SP0070 LH Fender Mount (1)



- SP0008 Hard Nose Weld Plate (2)

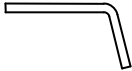

- SP0012 Cab Weld Plate (2)



- SP0160 Sweep Body (1)



*\*The following parts are pre-bolted to the Sweep Body and Fender Mounts.*

- 1" x 4-1/2" Bolt (8)
- 1" Lock Nut (8)
- 9S5187D Rubber Mount (8)



- 8P5244D Rubber Washer (16)



- SP0002 (4)



*\*\*All fasteners are Grade 8*

## Installation

- Measure distance between front of Sweep body and then center Hard Nose Weld Plates onto Hard Nose. Weld Hard Nose Plates (SP0008) centered with distance previously measured onto Hard Nose. See Picture Below...



- Measure distance between Cab end of Sweep body and then center Cab Weld Plates on Cab. Weld Cab Plates (SP0012) centered with distance previously measured onto Cab.
- Use a hoist and lift the Sweep body (Part# SP0160) into place on the weld pads. Weld the U-brackets of Sweep body to weld pads. See figure & photo below...

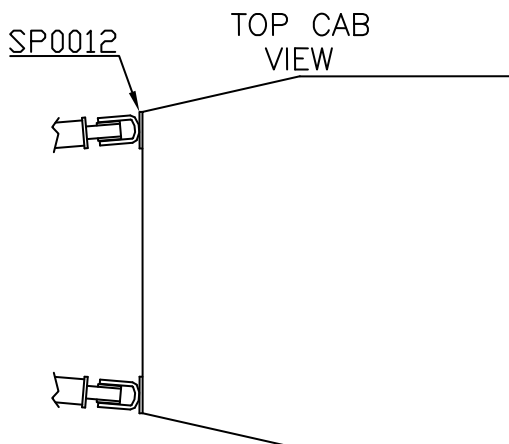

- Using (2) 1-1/2" wrenches & a rubber mallet, remove the 1" bolts that fastens legs to Sweep body.
- Use a hoist to suspend Fender Mounts. Bolt Legs to Sweep Body using (2) 1-1/2" wrenches & a rubber mallet. Weld RH & LH Fender Mounts (Part#s SP0069 & SP0070) to Fenders as seen below...



- Tighten all bolts securely.

**Thank you for your purchase.**

**Any questions or comments can be directed to  
1-800-445-1917**