

HS23 – D5M EROPS (ROLLBAR)

PARTS LIST:

1. SP0045	3" LH SWEEP ARM	1 PC
2. SP0046	3" RH SWEEP ARM	1 PC
3. SP0047	2" CROSS TUBE	1 PC
4. SP0048	2" CROSS TUBE	1 PC
5. SP008	HARDNOSE PLATE	2 PCS
6. 5Q8328D	BLOCK	2 PCS
7. 5Q8478D	LIGHT BRACKET (<i>optional</i>)	2 PCS
8. SP0002	U- BRACKET	2 PCS
9. 9S5187D	RUBBER BUSHING	2 PCS
10. 1" X 5" NC	BOLT	2 PCS
11. 1" NC	LOCKNUT	2 PCS
12. M10 X 1.5 X 90 MM	BOLT	8 PCS
13. 10 MM	WASHER	8 PCS
14. 3/8" NC X 1"	BOLT (<i>for optional light bracket</i>)	4 PCS
15. 3/8" NC	LOCKWASHER (<i>for optional light bracket</i>)	4 PCS
16. 1" X 4-1/2" NC	BOLT	2 PCS
17. 1" NC	LOCKNUT	2 PCS

Installation Instructions

Step 1 Bolt mounting blocks (5Q8328D) to the rollbar using the 8 bolts (M10 X 1.5 X 90 MM) and the 8 washers (10 MM). The bolts should not be tightened at this time. See drawing below.

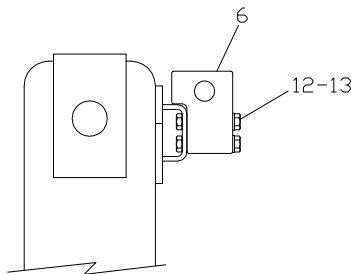

Step 2 Place the hardnose plates (SP0008) on the hardnose, spacing them 14-1/2" off the center of the hardnose as indicated the drawing below. Tack weld the plates to the hardnose.

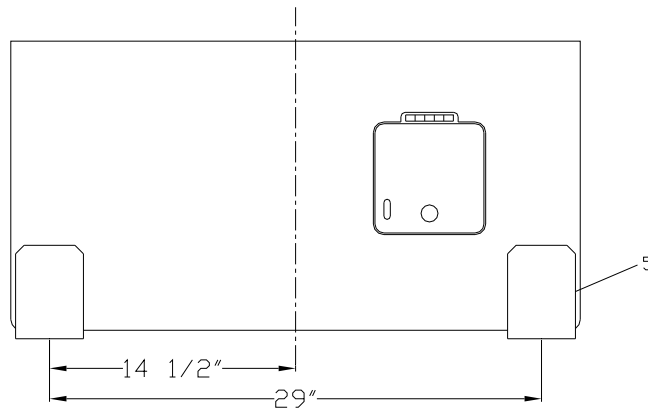

Step 3 Place the RH & LH sweep arms (SP0045 & SP0046) in place on the machine. The sweep arms have been notched out to fit over the mounting blocks. The sweep arms need to be placed on top of the mounting blocks. This will be a tight fit. Align the holes in the sweep group and the mounting blocks and use the 2 bolts (1" X 5" NC) and the 2 locknuts (1" NC) to secure them together. The bolts should not be tightened at this time.

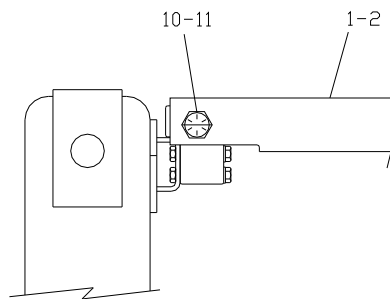

Step 4 Go back to the hardnose end of the sweep group and fit the 2 rubber bushings (9S5187D) into the stobs of the sweep group and then bolt the U- brackets to the stobs using the 2 bolts (1" X 4-1/2" NC) and 2 locknuts (1" NC). The bolts should not be tightened at this time. The U-brackets should be sitting on the hardnose plates as indicated in the view below.

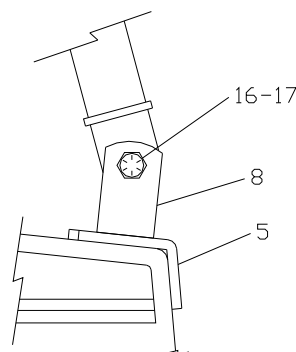

Step 5 Now tack weld U-Brackets to Hardnose and tack weld cross tubes in their appropriate places as seen in view below.

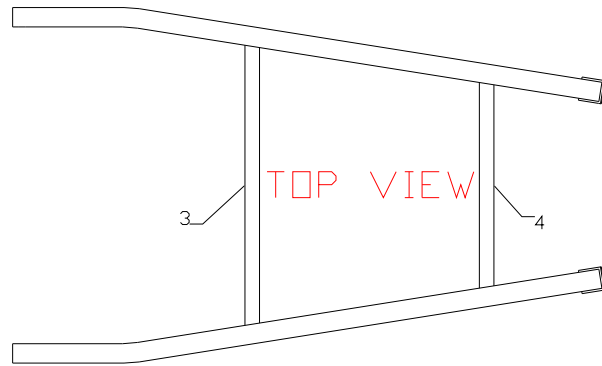

Step 6 Now that everything is basically in place, you should go back and tighten all bolts and weld out the hardnose plates, U- brackets & cross tubes. All welds should be minimum ¼” fillet weld.

Step 7 (*Optional*) These 2 light brackets bolt up to the bottom side of the mounting blocks using the 4 bolts (3/8” NC X 1”) and the 4 lock washers (3/8” NC). This is an optional bracket depending on whether or not you have lights to mount.

